



DOWNTIME is NOT an OPTION

Industrial Fans & Blowers

Ideal application for automatic lubricators

Fan systems are a critical component in industrial applications for various purposes from exhausting heat and gases and cooling, to dust collection and material handling. As most maintenance managers know, when one of these fans stops working due to bearing failure, it can set off a chain reaction that shuts down production lines resulting in expensive downtime. These failures can also create a hazardous work environment. So, to ensure uninterrupted long-term equipment operation it is critical to regularly lubricate fan system bearings.

Main lube points on a fan system Motor and Shaft Bearings

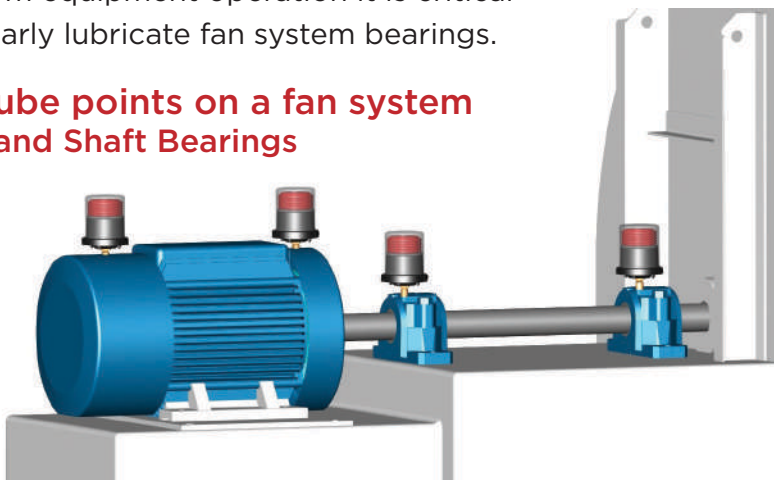

The root causes of fan system bearing failure:



Inadequate lubrication

Over- or under-lubricating the bearings.



Hard to reach and hazardous areas

Fan systems are often located in areas that are hazardous or inaccessible creating safety issues that delay or reduce regular bearing lubrication duties.



Labor intensive

Manufacturing facilities can have many fan systems onsite. Because each lube point needs regular lubrication the job becomes time and labor intensive and can be deferred to other projects.



Best practice is to relubricate the bearings with smaller grease quantities at more frequent intervals while the equipment is running. Our automatic lubricators offer solutions for a wide range of difficult applications from direct or remote mount single-point lubricators to multi-point systems to meet your needs.

SINGLE-POINT LUBRICATORS



- Direct-mount, single-point lubricator
- Low-cost single-use electrochemical unit
- Simple dial-set programming
- Easy installation
- Suitable for use in all hazardous-rated locations



- Direct- or remote-mount installation
- Robust, reusable electromechanical unit
- Flexible programming and power options
- Versatile mounting ability
- Suitable for use where ambient temperatures vary

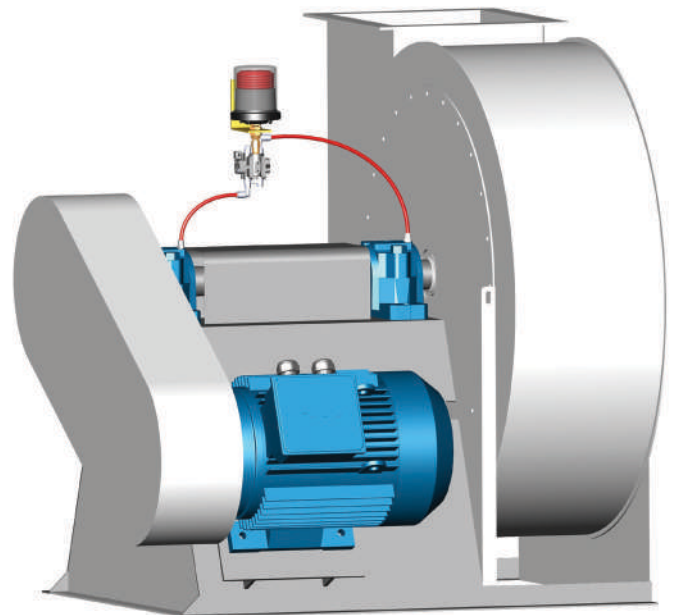

MULTI-POINT LUBRICATORS



- Economical alternative to larger centralized lube systems
- Precise and consistent lubrication of multiple points using one lubricator
- Facilitates safe lubrication of multiple hard-to-reach lube points
- Promotes significant cost-savings over manually lubricating the same number of lube points
- Industrial-grade design for all-weather operation



DISTRIBUTOR:

INC NITIN CORPORATION

402, 4th Floor, Bezzola Commercial Complex,
V.N. Purav Marg, Sion-Trombay Road,
Chembur, Mumbai – 400071,
INDIA.

+91-9920404345
aditya@corponit.com
nitincorporation@yahoo.com